



PW-10P-MD

DIMENSIONAL SCHEMATIC AND PERFORMANCE

DIMENSIONS mm

not to scale
specifications are subject to change

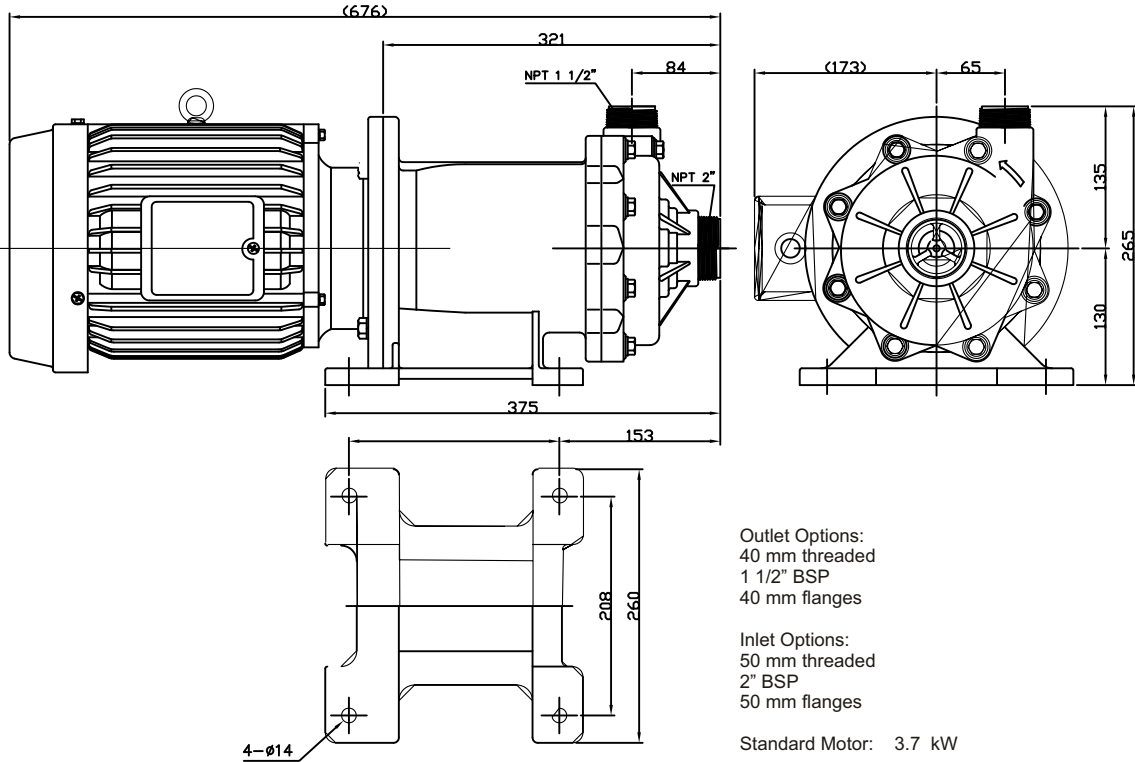

Outlet Options:
40 mm threaded
1 1/2" BSP
40 mm flanges

Inlet Options:
50 mm threaded
2" BSP
50 mm flanges

Standard Motor: 3.7 kW

Details may change depending upon the motor specified

PERFORMANCE

Tests obtained
50 hz 2860 rpm
— 1.2 SG
— 1.5 SG

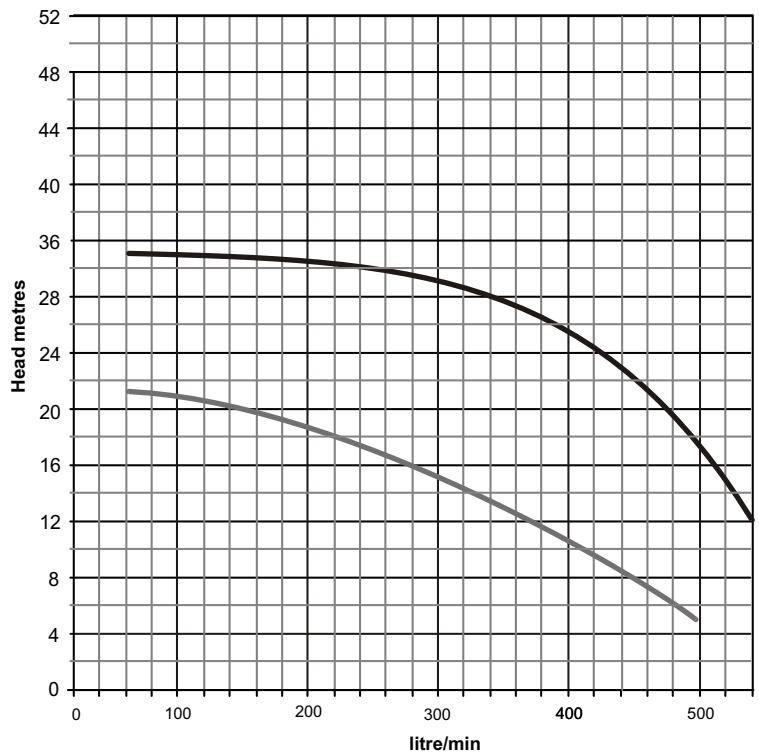

Performance may change depending upon the motor specified