



HTP-B

DIMENSIONAL SCHEMATIC, PERFORMANCE AND PARTS LIST

DIMENSIONS mm

not to scale
specifications are subject to change

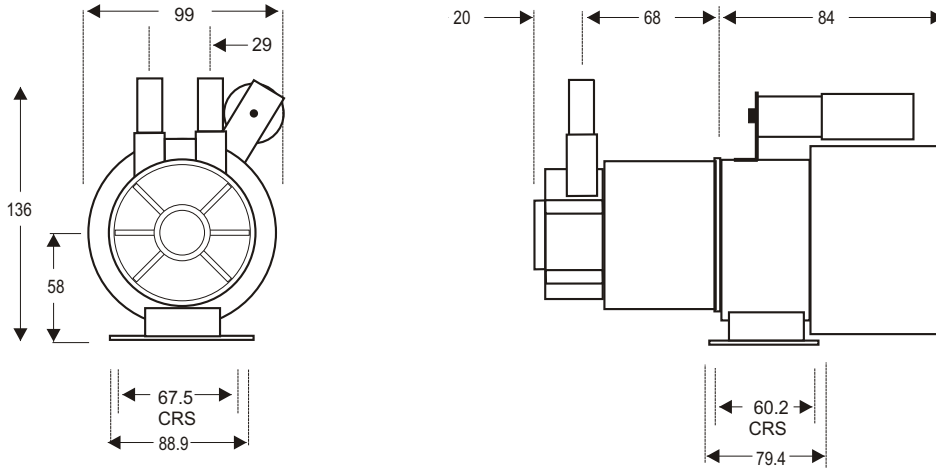

Details may change depending upon the motor specified

PARTS LIST

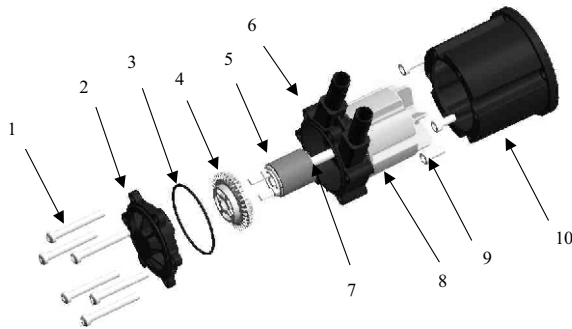

ITEM	DESCRIPTION	NOS	CODE
1	HOUSING SCREWS ST/STEEL	4	5002-120-30
2	FRONT COVER	1	5022-2101-50
3	O RING - NITRILE	1	5002-120-30
4	TURBINE	1	5025-131-14
5	IMPELLER MAGNET	1	5025-191-08INN
6	SPINDLE STAINLESS STEEL	1	5025-100-51
7	PUMP HOUSING	1	5025-141-09
8	DRIVE MAGNET HI TORQUE	1	5025-203-00
9	MOTOR BRACKET	1	5025-170-01
10	BRACKET FIXING SCREWS	1	5090-512-50CAI

PERFORMANCE

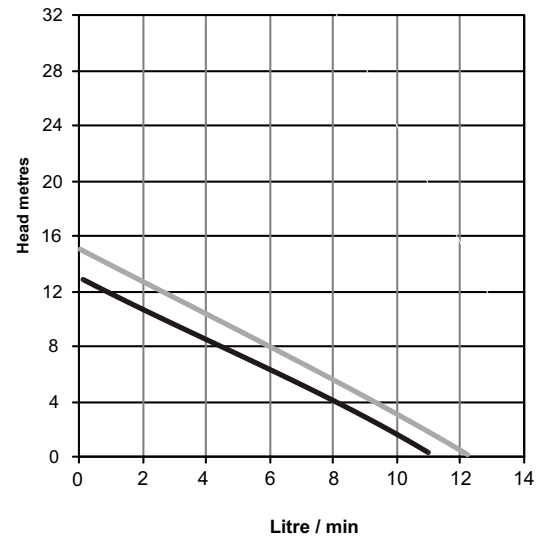

Tests obtained with water 1.0 SG

— 50 hz 2900 rpm
— 60 hz 3400 rpm